

New

Electric Control Valves

1½", 2", 2½", 3", 4" & 6"

The new Electric Control Valves feature a hydrodynamically optimized design that delivers superior KV/CV performance, exceptionally high flow efficiency, minimal pressure loss, and operate silently and vibration-free.

The valves are precision-engineered using a polymer body reinforced with fiberglass and a diaphragm of rubber reinforced with specialty woven fabric, ensuring robust durability and consistent high performance in agricultural, landscape, greenhouse, and industrial applications.



HIGHLIGHTS

- **High Flow Efficiency:** The innovative internal design delivers a high flow coefficient, reducing opening pressure while increasing flow capacity and minimizing pressure loss
- **Flexible Operation:** Equipped with a fabric-reinforced diaphragm, the valve ensures smooth operation, tight shut-off and no distortion.
- **Durable Construction:** Made from polymeric materials, the valve offers excellent durability, corrosion resistance and long service life, even in a harsh environment.
- **Rapid Response:** The valve responds quickly to pressure changes, ensuring stable performance without vibration or distortion.
- **Simplified Design:** With only 4 main parts, the valve is easy to maintain, providing reliable operation and simplified servicing.
- **End Connections:** The valves can be equipped with threaded, grooved, or flanged connections for easy and flexible installation across different systems

APPLICATIONS

- **Agriculture & Landscape Irrigation:** Designed for efficient water management in large-scale irrigation systems.
- **Industrial & Waterworks:** Used in water treatment plants, wastewater systems, and other industrial applications where flow control is critical,
- **Greenhouse & Turf Irrigation:** Ideal for precise irrigation in controlled environments ensuring optimal water distribution.



Technical Data

Valve Size	mm	40 mm H	50 mm	65 mm R	80 mm R	80 mm	100 mm R	100 mm	150 mm R	
	Inch	1.5" H	2"	2.5" R	3" R	3"	4" R	4"	6" R	
		1.5 x 2 x 1.5	2 x 2 x 2	2.5 x 2 x 2.5	3 x 2 x 3	3 x 3 x 3	4 x 3 x 4	4 x 4 x 4	6 x 4 x 6	
Maximum Flow Rate	m ³ /hr	40	60	75	90	140	140	180	180	
	gpm	176	264	330	396	616		792		
Minimum Flow Rate	m ³ /hr	>1								
	gpm	>5								
Pressure Range	bar	0.5 - 10						0.7 - 10		
	psi	8 - 145						10 - 145		
Flow Rate Factor	Kv (metric)	60	86	90	90	170		280		
	Cv (US)	70	100	104	104	197		324		

R = Reduced port

Maximum Operating Temperature : 60 °C (140 °F)

Performance Graphs

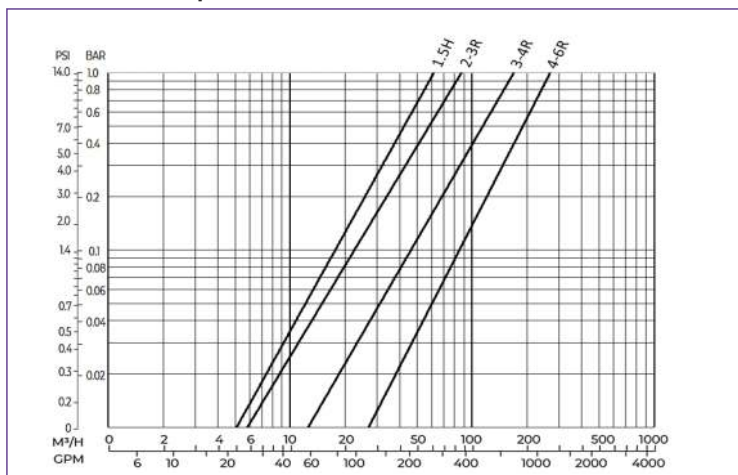

Engineering Data

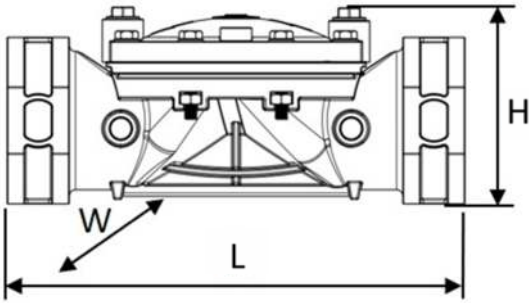

Threaded (1.5"H – 3")

Valve Size		1.5" H / 40 mm H Threaded	2" / 50 mm Threaded	2.5" R / 65 mm Threaded	3" R / 80 mm Threaded	3" / 80 mm Threaded	
		1.5 x 2 x 1.5	2 x 2 x 2	2.5 x 2 x 2.5	3 x 2 x 3	3 x 3 x 3	
Dimension							
Height	H	mm	103	103	110	116	121
		Inch	4 ¹ / ₁₆	4 ¹ / ₁₆	4 ²¹ / ₆₄	4 ⁹ / ₁₆	4 ⁴⁹ / ₆₄
Width	W	mm	137	137	137	137	175
		Inch	5 ²⁵ / ₆₄	5 ²⁵ / ₆₄	5 ²⁵ / ₆₄	5 ²⁵ / ₆₄	6 ⁵⁷ / ₆₄
Length	L	Mm	201	201	261	261	290
		Inch	7 ²⁹ / ₃₂	7 ²⁹ / ₃₂	10 ⁹ / ₃₂	10 ⁹ / ₃₂	11 ²⁷ / ₆₄

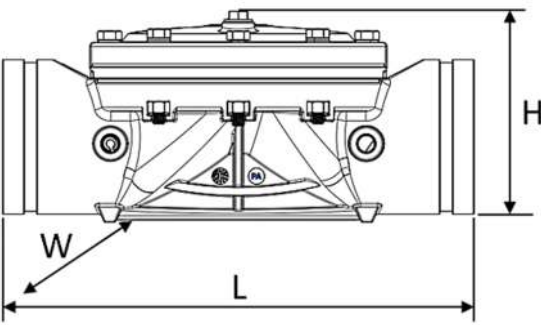

Grooved (3"R – 6"R)

Valve Size		3" R / 80 mm R	3" / 80 mm	4" R / 100 mm R	4" / 100 mm	6" R / 150 mm R	
		3 x 2 x 3	3 x 3 x 3	4 x 3 x 4	4 x 4 x 4	6 x 4 x 6	
Dimension							
Height	H	mm	110	118	127	158	173
		Inch	4 ²¹ / ₆₄	4 ⁴¹ / ₆₄	5	6 ⁷ / ₃₂	6 ¹³ / ₁₆
Width	W	mm	137	175	175	240	240
		Inch	5 ²⁵ / ₆₄	6 ⁵⁷ / ₆₄	6 ⁵⁷ / ₆₄	9 ²⁹ / ₆₄	9 ²⁹ / ₆₄
Length	L	mm	247	290	290	350	420
		Inch	9 ²³ / ₃₂	11 ²⁷ / ₆₄	11 ²⁷ / ₆₄	13 ²⁵ / ₃₂	16 ¹⁷ / ₃₂

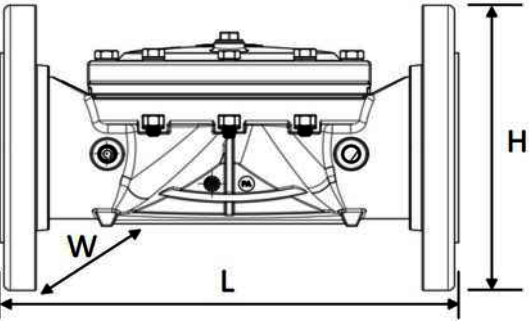

Flanged (3"R – 6"R)

Valve Size		3" R / 80 mm R	3" / 80 mm	4" R / 100 mm R	4" / 100 mm	6" R / 150 mm R	
		3 x 2 x 3	3 x 3 x 3	4 x 3 x 4	4 x 4 x 4	6 x 4 x 6	
Dimension							
Height	H	mm	203	203	230	230	300
		Inch	7 ⁶³ / ₆₄	7 ⁶³ / ₆₄	9 ¹ / ₁₆	9 ¹ / ₁₆	11 ¹³ / ₁₆
Width	W	mm	203	203	230	240	300
		Inch	7 ⁶³ / ₆₄	7 ⁶³ / ₆₄	9 ¹ / ₁₆	9 ²⁹ / ₆₄	11 ¹³ / ₁₆
Length	L	mm	247	297	297	357	427
		Inch	9 ²³ / ₃₂	11 ¹¹ / ₁₆	11 ¹¹ / ₁₆	14 ¹ / ₁₆	16 ¹³ / ₁₆

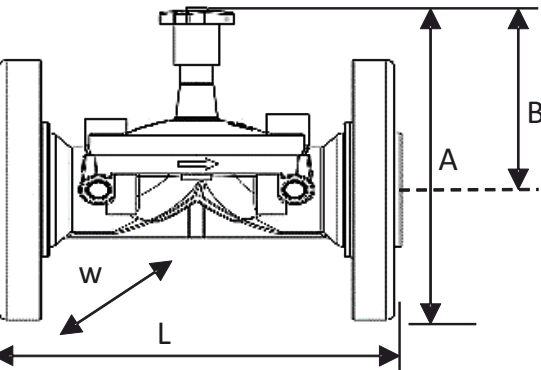

With Manual Throttling (1.5"H – 3"R)

Valve Size		1.5" H / 40 mm H Threaded	2" / 50 mm Threaded	2.5" R / 65 mm Threaded	3" R / 80 mm Threaded	3" R / 80 mm Grooved	3" R / 80 mm Flanged	
		1.5 x 2 x 1.5	2 x 2 x 2	2.5 x 2 x 2.5	3 x 2 x 3	3 x 2 x 3	3 x 2 x 3	
Dimension								
Height	A	mm	184	184	191	197	191	251
		Inch	7 ¹ / ₄	7 ¹ / ₄	7 ³³ / ₆₄	7 ⁷ / ₁₆	7 ³³ / ₆₄	9 ⁷ / ₁₆
	B	mm	NA					
Width	W	mm	137	137	137	137	203	
		Inch	5 ²⁵ / ₆₄	5 ²⁵ / ₆₄	5 ²⁵ / ₆₄	5 ²⁵ / ₆₄	5 ²⁵ / ₆₄	7 ⁶³ / ₆₄
Length	L	mm	201	201	261	261	247	247
		Inch	7 ²⁹ / ₃₂	7 ²⁹ / ₃₂	10 ⁹ / ₃₂	10 ⁹ / ₃₂	9 ²³ / ₃₂	9 ²³ / ₃₂

Control Valves Types



Manual Control Valve

The valve is controlled manually by a 3 Way Brass Selector that allows the user to select either “Open”, “Close” or “Auto” port. On selecting the “Close” port, the valve remains in closed position. On selecting “Open”, the valve remains in open position. The “Auto” port is used in regulating configurations with a Pilot. The operation of the valve with the 3-Way selector is quick and effortless even under high pressure conditions.



2 Way Electric

Electrically actuated, it is a normally closed valve with an in-built solenoid actuator. The simplicity of the valve makes it suitable for greenhouse and field irrigation applications. They come equipped with AC or DC latch operators and a manual override is enabled through an integral lever.



3 Way Electric

The 3 Way solenoid valve is actuated by an electric current or an electric pulse (latch) that opens or closes the main valve. The valve is supplied as “Normally Closed”.



Quick Pressure Relief Valve (2 Way Pilot Operated)

The Quick Pressure Relief Valve is a hydraulically operated, diaphragm actuated control valve that relieves excessive system pressure that rises above the maximum pre-set. Equipped with a 2 way diaphragm actuated spring loaded pilot, the reaction of the valve is immediate, accurate and offers high repeatability by fully opening. The Quick Pressure Relief Valve provides smooth drip tight closing once pressure reduces below the pre-set.



Pressure Reducing Valve (3 Way Pilot Operated)

The valve maintains a pre-set downstream pressure regardless of upstream pressure or flow fluctuations, controlled by a 3-way pilot valve. The spring loaded membrane of the pilot is sensitive to downstream pressure and maintains desired downstream pressure by gradually opening and closing the hydraulic valve. When no flow exists in the system, the valve closes itself automatically.



Pressure Sustaining Valve (3 Way Pilot Operated)

Pressure sustaining valve installed in-line, sustains minimum back pressure controlled by a 3-way pilot. The spring loaded membrane of the pilot is sensitive to upstream pressure and opens the valve when the inlet pressure exceeds pilot set pressure. The valve will be in closed position, if upstream pressure is below the desired set pressure.



Electric Pressure Reducing Valve (3 Way Pilot Operated)

The valve maintains a pre-set downstream pressure regardless of upstream pressure or flow fluctuations, controlled by a 3-way pilot valve. The valve opens to modulate and shuts off in response to an electrical signal.



Electric Pressure Sustaining Valve (3 Way Pilot Operated)

Electric pressure sustaining valve installed in-line, sustains minimum back pressure controlled by a 3-way pilot. The spring loaded membrane of pilot is sensitive to upstream pressure and opens the valve when the inlet pressure exceeds pilot set pressure. The valve by default is normally open and operates to sustain inlet pressure when electric command is given to the solenoid.